

Applications of Contact

Contact Mechanics – Lesson 4



Bowling Pins

- Bowling is a recreational activity where a heavy ball is thrown toward a set of pins that are arranged in a triangular form. The objective is to knock down all the pins.
- This game dates to 5300 B.C. during the Egyptian times.
- The key to winning the game is transferring momentum to all the balls.
- Since the balls and pins are all individual entities, contact is required to transfer this momentum between the parts.

Bowling Pins (cont.)

- In this example, we will model this collision and investigate two cases: one with a contact formulation defined and another without any contact formulation.

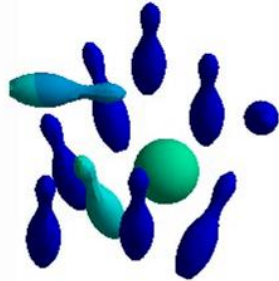

With Contact

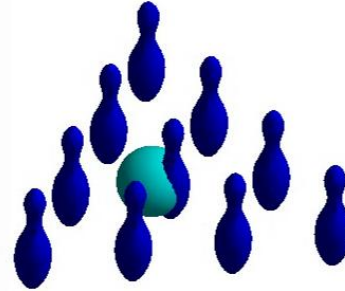

Without Contact

- This is a simple example that demonstrates what is needed for defining contact between the bodies to model interaction between them.

Belt Drive

- A belt drive is commonly seen in mechanical systems for power transmission.
- It usually has a flexible belt that runs over two or more shafts, and the friction between the shaft and the belt helps in transferring power from one shaft to another.
- The belt usually transitions from stick to slip state while transferring power.



Belt Drive (cont.)

- The belt is stretched between the shafts so the stress in the belt will increase the contact pressure between the shaft and the belt.
- After this step, one of the shafts is rotated and the power is transmitted to the other.

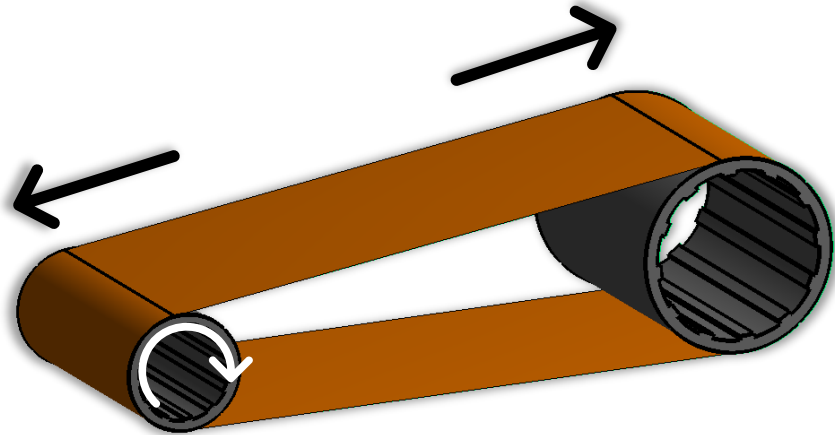

Belt Drive (cont.)

Now, let's simulate this scenario for two different cases

1. With friction
2. Without friction

Since friction is a key component, we should see a stark difference in the response.

Belt Drive (cont.)

- As we can see from these animations, in case of frictional contact, the power is transmitted between the shafts.
- In case of frictionless contact, the belt simply slips over the driver shaft and does not transmit the power to the driven shaft.

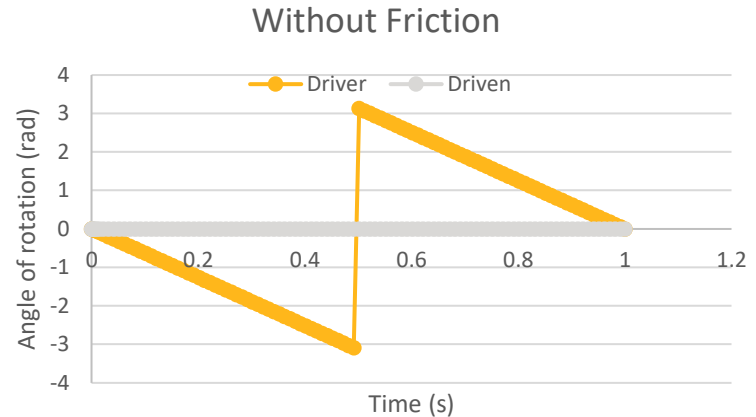
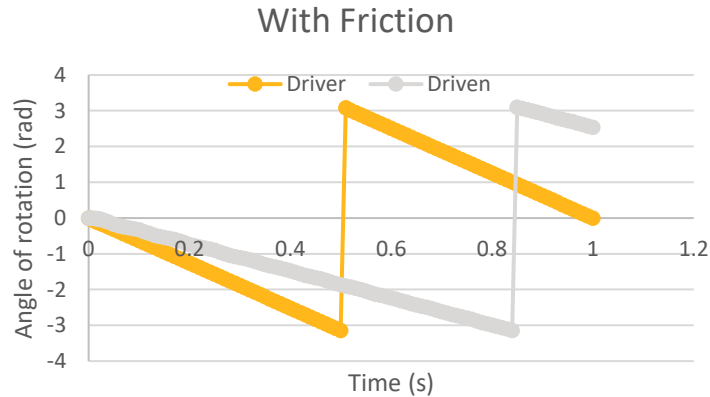

O-Ring

- O-rings are commonly used to seal the gaps between engaging parts.
- It's a gasket generally made of an elastomer in the shape of a torus.
- The performance of an O-ring is assessed based on the contact pressure that is created at the interface during operation.
- In this example, we will explore the design of an O-ring system which is designed to seal a pressurized fluid.
- Under the action of the fluid the O-ring is expected to deform but support the applied pressure.

O-Ring (cont.)

- In the first design, we have the O-ring installed between two steel components.
- After installation, a fluid pressure of 50 MPa is applied on the O-ring to see if it can withstand the applied pressure.
- In this case, a frictional contact is used between the O-ring and the steel components.
- The quantity of interest is the contact pressure between the O-ring and the steel components.

O-Ring (cont.)

- In this example we investigate two different designs of the system.
- In Design 1, the lower component has a flatter base and a fluid pressure of 50 MPa is applied on the O-ring.
- In Design 2, the lower component has an inclined base and a fluid pressure of 70 MPa is applied on the O-ring.
- In both designs, we will also see how the choice of contact formulation can affect the accuracy of results.

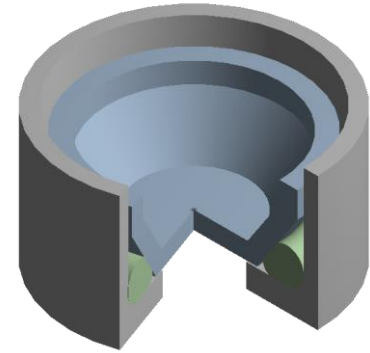

Design 1

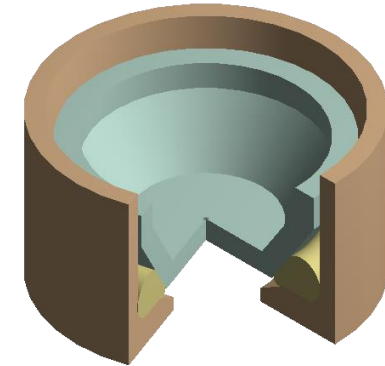

Design 2

O-Ring (cont.)

- Let's investigate design 1.
- We'll compare the contact pressure in the design calculated using both penalty and Lagrange formulations.
- From the results, we observe that there's very little difference in the contact pressure between the two formulations.



O-Ring (cont.)

- Now, let's do a similar comparison for design 2.
- In this case, there's almost 15% difference in the max. contact pressure calculated by both the formulations.

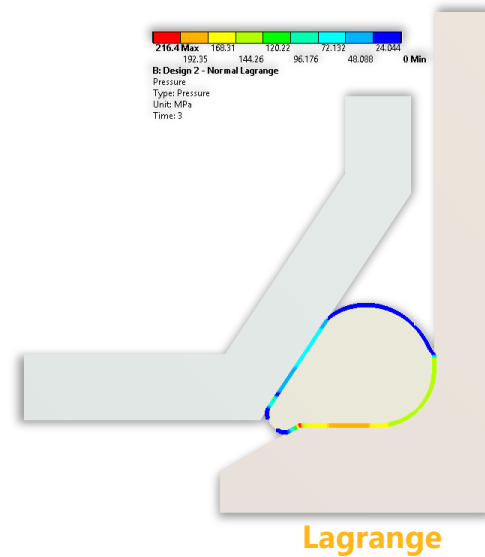
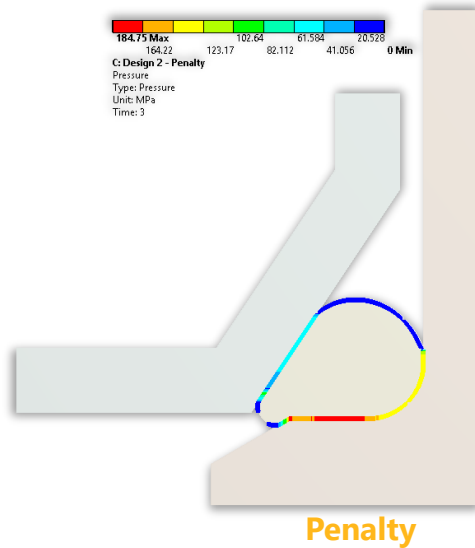

O-Ring (cont.)

- This can be explained by comparing the total penetration at the contact between the two methods.
- We can see that the model with penalty formulation results in penetration whereas Lagrange formulation does not suffer from such an issue.

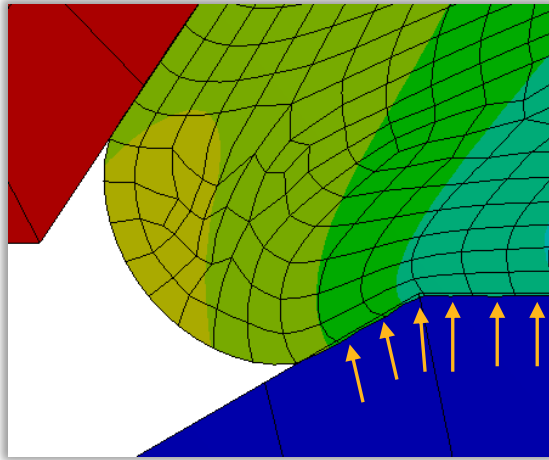

Penalty

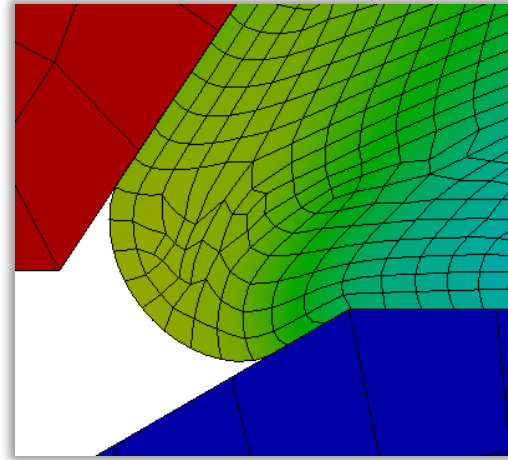

Lagrange

O-Ring (cont.)

- In design 2, the change in design of the base introduces a sharp corner over which the material flows.
- As a result, the penalty formulation would require large contact stiffness to avoid penetration.
- A Lagrange formulation, on the other hand, imposes a zero-penetration constraint so it captures the flow of material over a sharper corner more accurately.
- This simple examples shows that one formulation may be beneficial over another depending on the design or application.

Ansys

